

AUSTER NEWS

Published by AUSTER AIRCRAFT Limited
REARSBY AERODROME · LEICESTER · ENGLAND



Vol. 5 : No. 10

“... and the electric power system is BTH throughout”



Aircraft manufacturers take no chances with electrical equipment. They specify BTH, relying on the reputation this firm's products enjoy in every branch of engineering. BTH design complete electrical

power systems and supply the appropriate equipment, including: ac and dc motors and generators, motor-generating sets with electronic regulators, gas-operated turbo-starters, Mazda lamps, etc.



leading manufacturers incorporate

BRITISH THOMSON-HOUSTON

electrical equipment for aircraft



Rearsby,
December, 1955.

To all our readers.

We take this opportunity of sending you our greetings for Christmas and wishing you every success in the coming year.

Our hope is that 1956 will be another peaceful year in the many countries whose borders are so frequently crossed by light aircraft owners. Goodwill tours, flying holidays and rallies, do much to foster international friendship.

With best wishes from all at Rearsby.



Cover Photo

Wedge-tails beware! This unusual picture was taken in Australia and shows, rather dramatically, Mr. R. G. Casey, Australia's External Affairs Minister, trying his hand at eagle shooting from an Auster. Mr. Casey was visiting Bundoran sheep station, Richmond, run by the Morton brothers who own the Auster in the photograph. It appears that this aircraft is quite a work horse, being used for boundary inspection, sheep mustering, mail delivery, and, of course, general communication duties. It has already flown over 100,000 miles without mishap.

Eagle shooting is practised by the Morton brothers in an attempt to preserve the lambs on their property, hundreds of which are carried off by the birds. More than 260 Wedge-tails have already been shot.

A "Courier Mail" photo.

The press are welcome to utilise any of the subject matter in this issue of the Auster News with, or without acknowledgement.

TEN YEARS IN MALAYA

. . . a busy time for 656 Squadron

Not a great deal is generally known about the activities of British Air O.P. Squadrons which at present are stationed at points all over the world. The following account serves well to show the many duties carried out by such units. The story utilises information provided by the Officer Commanding No. 656 Air O.P./LL Squadron, Major A. F. Robertson, R.A., and Mr. L. A. Leatham, assistant test pilot, of Auster Aircraft. Mr. Leatham gained considerable experience flying the Auster A.O.P.9 during the routine testing of the aircraft, he recently returned from Malaya, having introduced the aircraft to No. 656 Squadron.

Received Surrender Sword

Friday, the ninth of September, 1955, besides being Amnesty day was a significant day in the history of 656 AOP/LL Squadron, R.A.F. Exactly ten years before on the ninth of September, 1945, A and C Flights of 656 Squadron, taking part in operation "Zipper" landed in the Sepang and Morib areas of Selangor. Shortly afterwards, the Squadron Commander, Major D. W. Coyle, M.B.E., D.F.C., R.A., landed at R.A.F. Kuala Lumpur, and to his surprise, was met by the local Japanese Commander, who offered the immediate surrender of all enemy forces in the city. A short ceremony followed, and the Japanese sword offered as a token of surrender, hangs to this day in the Squadron Commander's office at Noble Field.

The Squadron then consisted of Squadron Headquarters, A, B and C Flights, and was mainly occupied with communication flying. Early in 1946 the Squadron moved to Java where trouble started to develop. The Auster Mark 5's, with which the Squadron

was then equipped were put to a novel use. Fitted with bomb racks and small bombs they assumed a somewhat more aggressive role against the rebels. After nearly a year in Java, the Squadron returned to Malaya and disbanded, except for one flight which became 1914 AOP Flight and is now the senior flight in the Squadron.

No. 656 Squadron reformed on the outbreak of the Malayan emergency and was made up of Squadron Headquarters, 1902, 1903, 1907 and 1914 Flights. 1903 Flight later moved to Hong Kong and Korea, in which latter theatre it served with great distinction. 1903 Flight was replaced in Malaya with 1911 Flight. Today 1902 and 1914 are Air O.P. Flights manned mainly by Royal Artillery and R.A.F. personnel. 1907 (who recently flew their 25,000th hour) and 1911 are Light Liaison Flights and are manned by Glider Pilot Regiment and R.A.F. personnel. In war the distinction between the two types of flights would be marked by virtue of differing tasks. In Malaya all flights carry out similar tasks which are peculiar to the country and type of operations carried out against the terrorists.

6 Million Leaflets dropped

The duties undertaken are many and varied. They involve supply drops of almost any article from stores to such assorted items as crosscut saws, axes, explosives for landing zone clearance, mortar base-plates, and even stretchers. Leaflets totalling over 6 million have been dropped with pinpoint precision upon terrorist and aborigine camps spotted amongst the featureless jungles and swamps. Austers of this Squadron have developed to



Auster A.O.P. Mk. 9 aircraft are now in service in Malaya, two are seen here on patrol above the mist covered jungle.

a fine degree target marking by day and night for R.A.F. bombers dropping more militant loads.

The pilots of this unit are composed of Army Officers, Warrant Officers and N.C.O.'s who serve a three-year period amassing a total of 1,800/2,000 flying hours. Flying from a small rough air strips their usual day-to-day duty is visual reconnaissance of an area of approximately 100 square miles, patrolled until each pilot knows his area to a degree which ensures that the slightest terrorist activity or food cultivation clearing is instantly spotted.

This requires great skill and perseverance, for besides examining the ground in detail the pilot must fly his aircraft, read a map, work two wireless sets and keep a wary eye on the weather. A task much appreciated by the Infantry is the contact reconnaissance. The patrol in the jungle on hearing the Auster, puts up smoke. The pilot then fixes the position of the patrol on the map and radios this, together with

instructions for reaching the objective, to the patrol on the ground. Most pilots are thankful that theirs is not the uncomfortable lot of the infantry, who take many hours to cover a distance which can be flown over in seconds.

Weather conditions are not the most suitable for such light aircraft, sudden tropical thunderstorms covering vast areas leap from nowhere with no warning, and the mountains produce hill and valley fog equally unpredictable.

The monsoons need no elaboration here, but the "downdraught" season is an anxious time—an unwary pilot squeezing between cloud base and mountain ridge will find to his cost that these downdraughts can, will, and have forced aircraft into the treetops which reach 200 feet and sometimes more above ground level.* For this type of unintentional arrival amongst trees the structure of the Auster has

*See article "Jungle Survival School for Far East Air Force" on p. 12.

proved to be probably the safest possible—five pilots escaping with only minor bruises etc., after dropping into primary jungle—which means that after breaking through the canopy of branches at anything up to 200 feet above the ground there is still quite a long drop!

Austers Parked in the Open

The aircraft which have carried out this formidable task are Austers Mark 6 and 7. They are based at Taiping, Benta, Noble Field, Seremban and Sembawang, and when not flying are parked in the open subjected to all the rigours of the Malayan climate. Maintenance facilities are rudimentary, but despite this, the dozen or so R.A.F. ground personnel at each Flight succeed in maintaining very high serviceability, working long hours in the open. They have no swimming pools or super NAAFI's but obtain satisfaction in doing a good job. Every three months an aircraft returns to R.A.F. Kuala Lumpur for a "major" or "minor" servicing check. This is undertaken by the Mobile Servicing Section of the Squadron, and usually five or six aircraft are to be seen stripped to their component parts and looking rather like skeletons.

Several veteran machines are still doing yeoman service with the Squadron in Malaya, six having acquired a total of over 15,500 hours between them, and the local "oldest inhabitant"—not included in this "sextet of sloggers"—is Mk. 6 V.F.626, now honourably retired with a total of 3,477 hrs. 55 minutes.

During December of 1954 this squadron piled up a total of 2,318 hours, and one contributing factor was that although the weather was too bad to ferry the aircraft due for servicing back to the servicing section the flights still carried out their varied task to the tune of having 31 Austers out of a total of 31 all airborne on operational duties.

In addition, the more conventional

role of observation for the guns of 25 Field Regiment, R.A. and for ships of the Royal Navy is also undertaken. These and other tasks are so numerous that the Squadron normally flies 25 per cent. of the total flying hours logged by the whole of the Far East Air Force. On 5th October, 1953, the Squadron flew its 50,000 hour in support of Emergency Operations. The total is now nearly 100,000 hours, or expressed another way, is equivalent to flying an aircraft 332 times around the world.!

The Auster Mark 6 which has served so faithfully is at present being replaced by the Auster Mark 9. This has a completely redesigned airframe and a more powerful Blackburn Bombardier engine. These aircraft have arrived in the Squadron and are proving popular with pilots.

The Squadron takes its part in activities not connected with operations. The rifle shooting team at Kota Tinggi in 1954 won the Minor Units Falling Plate competition, and the following year Captain H. N. D. Pullen, Glider Pilot Regiment, won the Campbell Cup for the best individual rifle performance in Malaya. In February the Squadron won the Kuala Lumpur Garrison 6 a side hockey knock-out competition.

No article about 656 Squadron is complete without an up-to-date 'snake' story. Early this year an Auster of 1914 Flight was seen to carry out a rapid approach and touch down at Noble Field. Almost before the aircraft had stopped rolling an astonished ground crew saw the pilot leap out of the aircraft. It appears that as Captain P. T. A. Musters, R.A., was on 'finals' a snake appeared from beneath the instrument panels and made rude gestures. On landing a spirited chase took place, ending in the port wing where the snake was despatched by the versatile ground crew. Almost certainly the snake (about four feet long) belonged to a deadly species.

The Latest Military
Auster - the A.O.P.
Mk 9 - for Observation
and Liaison duties

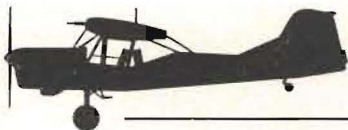

AUSTER decide on GOODYEAR

Auster Aircraft Limited have equipped the latest of their well-known aircraft with Goodyear. The latest military observation and liaison Auster, the A.O.P. Mark 9 is fitted with Goodyear tyres, wheels and brakes as standard equipment. The world over, more aircraft land on Goodyear tyres, wheels and brakes than on any other kind, confirmation of the fundamental superiority of Goodyear equipment.

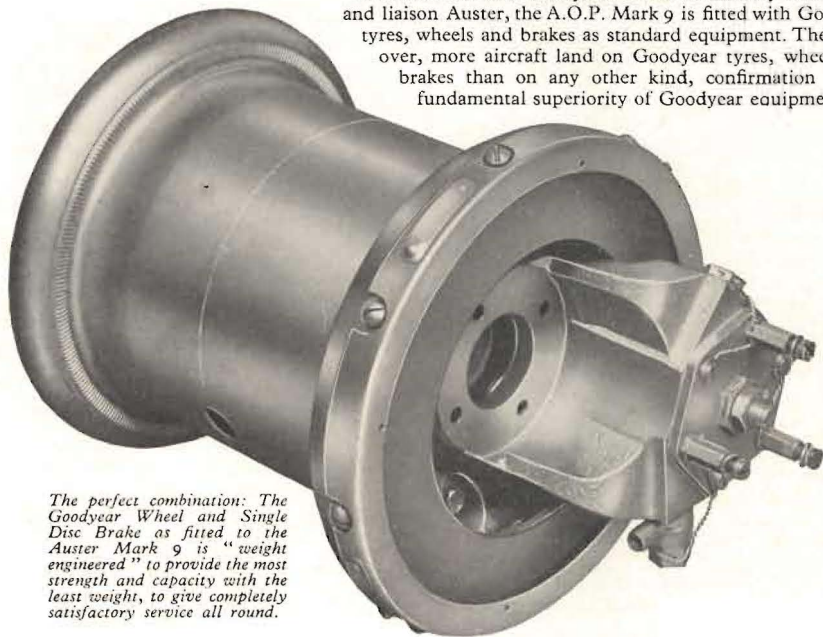

The perfect combination: The Goodyear Wheel and Single Disc Brake as fitted to the Auster Mark 9 is "weight engineered" to provide the most strength and capacity with the least weight, to give completely satisfactory service all round.

THREE REASONS WHY GOODYEAR IS BEST

LOWER COSTS

Long Life. Reduced spare parts inventory. Virtual elimination of line maintenance.

WEIGHT SAVING

Skilful design of every component gives maximum strength for minimum weight.

RELIABILITY

Proved by conclusive laboratory tests and the most extensive field experience.

WHEELS  **BRAKES**

THE GOODYEAR TYRE & RUBBER CO. (GT. BRITAIN) LTD., AVIATION DIVISION, WOLVERHAMPTON & WALLASEY

ANTARCTIC AUSTERS



THE use of lightplanes for Antarctic "route spotting" cannot be too highly emphasized. Aircraft chosen for this job must be light—for ease of manhandling, small—to occupy the least amount of space on an overcrowded expedition ship, and reliable—perhaps the most important factor when remembering that during an expedition the aircraft will be operating many thousands of miles away from organized repair facilities.*

To give readers some idea of the special modifications required on aircraft to be operated in sub-zero weather conditions, we have briefly outlined the most extensive of these.

Two aircraft have been produced for the Trans-Antarctic Expedition, basically they are Auster T. Mk. 7 types—the standard 2-seat Trainer with British Army Air O.P. units.

Cockpit

Side-by-side seating is provided for the crew, which may consist of a pilot and observer/photographer. Radio

**With the Trans Antarctic Expedition (see our previous issue).*

equipment mounted behind the observer's seat consists of a Marconi AD 97/108 lightweight H.F. aircraft transmitter/receiver. It is canted towards the pilot so that he may operate it more easily when flying solo. A drogue-type trailing aerial similar to that employed on the Auster Mk. 9 serves this radio. It has an extended length of 150 feet, and considerably increases the range of the radio.

An automatic direction finder AD. 7092, also by Marconi, is installed in the cabin as an aid to navigation in the featureless terrain. This equipment is more generally known as a radio compass, and features a loop aerial protruding through the top of the cabin canopy into a fairing. Emergency radio is provided for use in a dinghy with a kite-type aerial.

Normal Mk. 7 type cabin heating is used as it has proved adequate on previous Austers used for Polar re-

connaissance duties. Layout of the cabin has provided ample room for stowing the Arctic survival kit which will be carried during reconnaissance and photographic flights.

To allow for extremes of contraction and prevent cracking, all the cabin "perspex" is fitted using oversize rubber grommets of softer rubber than standard.

Alighting Gear

This may consist of either floats or skis both designed by the company. Wheels have been fitted, as will be seen in the adjacent photograph, these however were only to allow for flight testing at the airfield. No wheel flights are envisaged on the expedition.

The 17 ft. floats are of all light alloy construction except for pine-wood nose blocks covered with leather. A number of water-tight compartments are built into the floats, each having an inspection cover to check for condensation and leaks due to damage etc. Water rudders are fitted, and used only when taxiing. During take-off and landing, and beaching, they are retracted well clear of the undersides of the floats; in the first instance to prevent over-steer, and in the second to avoid damage. Actuation of the water-rudders is through the rudder pedals. When the floats are fitted an auxiliary fin is attached to the underside of the fuselage below the tail unit to counteract the additional area of floats forward of the C.G.

The skis, built of laminated ash, are fitted directly onto the normal axle in place of the main wheels. A small ski is also provided to replace the tail-wheel. The undersides of the skis are faced with bakelite-laminated fabric sheet to resist damage from abrasion. The undercarriage leg utilises rubber discs in compression. This type of leg was chosen for its excellent absorption

characteristics at very low temperatures. It was specially designed for use with the skis, from which no damping is forthcoming owing to the absence of the tyres. A bungee cord is attached to the nose of each ski, giving a nose-up attitude in flight and eliminating any trouble from "digging-in" at touch-down.

Airframe

A major difference between these aircraft and standard Auster Mk. 7 types is in the fitting of vertical tail surfaces of increased area, giving better handling characteristics and greater directional stability. Both the rudder and elevators are aerodynamically balanced. This, together with the larger area, will be of greater benefit when the aircraft is fitted with floats, especially during take-off.

A light-grade of tough fabric has been used to save weight, and the aircraft are finished in a brilliant orange dope to ease spotting them against the monotonous white surroundings.

Large trailing-edge static wicks are fitted to the control surfaces to discharge static electricity picked up during flight (these may be seen on the rudder in the photograph).

Engine and Fuel

A Plessey cartridge starter is used on the De Havilland Gipsy Major 7G engine (145 h.p.) which drives the Fairey metal propeller of fine pitch. An improved take-off performance will be achieved using this propeller which is not normally fitted on Mk. 7 aircraft. Special modifications have been carried out on the engine to ease engine starting in sub-zero conditions. An interesting point is that no oil cooler is fitted—it being found unnecessary in such a cold climate, hence a further saving in weight and drag.



A familiar sight to all pilots,
the aircraft servicing vehicles
of the Shell and BP
Aviation Service are on
duty all the year round at
the major airfields
in Britain.

AVIATION SERVICE



SHELL-MEX AND B.P. LTD., SHELL-MEX HOUSE, STRAND, W.C.2

Distributors in the U.K. for the Shell and Anglo-Iranian Oil Groups

MORE POWER for the Autocrat

MANY OWNERS of Auster J.1. Autocrat aircraft will be interested to learn that a very successful modification kit is now available, permitting the installation of the more powerful Gipsy Major 1 engine of 130 h.p. in place of the standard 100 h.p. Cirrus Minor 2 motor. This is a very practical proposition as many Gipsy Major 1 engines are still available throughout the world at reasonable prices. A much livelier all-round performance is the result, in particular, the shorter take-off run and faster climb characteristics should interest operators of Autocrats performing flying training and joy riding duties. Here, the extra power provides a more reassuring safety factor during peak engine performance with high loads.

The flying qualities of the modified Autocrat, which is known as the type J.1.N are considerably improved due to the replacement of the normal J.1 type vertical tail surfaces with a fin and rudder of greater area. The rudder incorporates an aerodynamic horn balance, and gives much better directional stability and control.

Performance tests show that for the considerable improvement in performance there is a comparatively slight rise in fuel consumption. From the 5 to 5½ gallons per hour on the Cirrus Minor Autocrat, to 6 to 6½ gallons per hour with the new Gipsy engined version is a very attractive figure to owners. It must also be borne in mind that the Gipsy overhaul life is at 1,500 hours as opposed to the 600 hour figure on the Cirrus Minor 2 and 800 hours on the Cirrus Minor 2A.

It should be understood that a Gipsy Major 1 engine intended for use in this conversion should be fitted with dual fuel pumps. In addition the engine requires slight modification to certain controls, to Auster drawing No. E.J.C.871 which is supplied with the modification kit. (In this installation

double scavenge pumps and oil cooler are not necessary for temperate conditions). A wooden propeller, Part No. D.H.5220/P25 or P26, is suitable and many of these also are available at reasonable prices. Alternatively, a metal propeller can be supplied giving an all-round improvement in the performance figures.

Two conversions have already been carried out, and in both cases the owners have ordered further modification kits to convert the remaining Autocrats in their fleets.

Production of parts for the conversion is now well under way, and delivery can be offered at 6-8 weeks from the receipt of orders. The total cost of the modification kit less propeller and engine is £230, quotations can also be made for the latter two items.

The complete conversion can be carried out at Rearsby, so why not fly in your old J.1 Autocrat and collect your J.1.N Autocrat by arrangement with the Auster Service Department, telephone Rearsby 321, Ext. 3.

AUSTER AUTOCRAT (Type J.1.N)

Performance at 2,000 lb. a.u.w. in standard conditions.

Powered by a Gipsy Major 1 engine.	
Take-off run (no wind) ..	168 yds.
Take-off run (5 m.p.h. wind)	135 yds.
Total to clear 50 ft. (no wind)	380 yds.
Total to clear 50 ft. (5 m.p.h. wind)	325 yds.
Landing run (no wind) ..	155 yds.
Landing run (5 m.p.h. wind)	125 yds.
Total landing distance from 50 ft. (no wind)	430 yds.
Total landing distance from 50 ft. (5 m.p.h. wind) ..	365 yds.
Initial rate of climb ..	710 f.t./min.
Time to climb to 5,000 ft. ..	8½ mins.
Service ceiling	15,000 ft.
Cruising speed at 2,100 r.p.m. at 1,000 ft. ..	105 m.p.h. I.A.S.
Max. speed at 1,000 ft. ..	126 m.p.h. I.A.S.
Fuel consumption at 2,100 r.p.m. cruise ..	6½ g.p.h. approx.



ANOTHER RECORD?

MANY of our readers, especially those in Australia, will remember the world-wide publicity given to the story regarding the Auster Autocar which took off without a pilot and lazily circled over Sydney before being shot down by Sea Fury fighters. Briefly what happened was, that the pilot swung the propeller and was considerably surprised when the engine burst into life, the aircraft gathered speed and took off to remain airborne for 2 hours 46 minutes with no one aboard, this was at 8.56 a.m. Circling Bankstown Aerodrome at about 15 feet and aided by a gentle breeze it slowly drifted towards Sydney where, upon arrival it had climbed to 1,000 ft. By this time Bankstown officials had alerted Sydney Airport who in turn warned all airborne aircraft in the vicinity, and then reported the matter to the Air Force and Navy. Fighter planes took off in pursuit and when the aircraft was over the sea two Naval Sea Furies fired several bursts of cannon fire into it before it crashed into the sea at 11.42 a.m.

Several Australian newspapers put forward the suggestion that this was a world record for a pilotless plane to remain airborne; well, we wonder?

38th PARALLEL

THE 1st Commonwealth Division Light Liaison Section, R.A.F. has the double

distinction of being the smallest station in the Far East Air Force and also the most distant R.A.F. unit from the British Isles.

It is 12,400 miles from London and located one mile south of Korea's 38th parallel. It is only $3\frac{1}{2}$ miles from the demilitarised zone, which divides the United Nations front-line from the Communist armies in the north.

Present strength of the station is 24—10 R.A.F. ground crew and 14 men of the Glider Pilot Regiment. In addition, 12 Korean soldiers are attached to the unit and come directly under the station commander.

The main role of the unit is to carry out reconnaissance flights along the frontier, and report Communist troop movements. Another major task is line-of-communication duties, senior officers and important stores are ferried between the division and base areas.

On divisional exercises and manoeuvres, the aircraft support Commonwealth Forces in the field, acting as 'the eyes' of the ground commander, and often dropping supplies to troop concentrations in the mountainous Korean countryside.

The station is a self-contained camp consisting of a large hangar and a collection of tents and Nissen-type huts grouped around the home-made control tower. The runway, built by the Royal Engineers, is considered the

best light aircraft airstrip in Korea. Over six thousand tons of rock were used in its construction.

ANOTHER AWARD FOR 656 A.O.P. SQUADRON

THE award of the Distinguished Flying Cross to Captain David Smith, the Royal Regiment of Artillery, No. 656 AOP/LL Sqdn. R.A.F., was announced during October in the "London Gazette." The citation states that:

"Captain Smith's enthusiasm for flying at all times and in any conditions, together with his skill and meticulous accuracy in providing information on terrorist activities have made an outstanding contribution to air operations during the emergency in Malaya."



Lt.-Col. J. K. Sarvanto, Finnish Military-Air-Naval Attache in London recently visited Rearsby to fly the Auster A.O.P. Mk. 9. He was very impressed by its performance and is seen here immediately after the flight.

WHAT'S YOUR LINE?

AMONGST our favourites is the one of the 656 A.O.P. Sqdn. pilot who complained that the Auster Mk. 9 could not be flown in as tight formation as the Mk. 6 because, "the pitot head on

the port wing tip would then be hitting the mainplane of the leader" — and — the salesman who claimed that the Auster ALPINE had such a rate of climb that the altimeter had to be viewed through a stroboscope!

A description of the Alpine, a new Auster type, will appear in the next issue of the "Auster News". Ed.

THE WORLD'S FASTEST PLUMBER?

WE hear it rumoured that Pat Sutherland of Kirkwall, Orkney, plans to use his Auster Mk. 5 aircraft to provide the "finest fastest plumbing service" in Scotland's western islands. Travelling at over 100 m.p.h. there should be no delays with his service.

A.O.P. EFFICIENCY AWARD

BACK to No. 663 Air O.P. Squadron goes the inter-squadron efficiency trophy for the fourth time. The squadron retained the trophy during 1951-52-53, but last year it was awarded to No. 664 Squadron based at Hucknall, Notts.

The C.O. of No. 663 Squadron is Major H. B. Warburton, M.B.E., D.F.C., R.A. The unit is based at Hooton, Nr. Chester, and operates Auster Mk. 6 and 7 aircraft.

ANTI-SMUGGLING AUTOCARS

FROM Captain Z. Yahya, chief pilot of the Iraq police force's customs aircraft, we have received a letter referring to the excellent service being given by the Auster aircraft they operate.

600 mile non-stop trips it appears are regularly undertaken during anti-smuggling patrols along the Kuwait/Iraq border and no failures or trouble with the aircraft have hindered operations. Regular readers will perhaps remember that these Austers supplied to the Iraq customs authorities, were equipped with stowage points for both Bren guns and rifles.

CIVIL DEFENCE TRY AUSTER/ RADIO LINK

USING an Auster Autocrat belonging to Mr. J. R. Ratcliffe of Derby, W/Cdr. P. J. H. Halahan, D.F.C., Chief Civil Defence Officer of the County Borough of Derby, has organised a series of tests to determine the usefulness of aircraft for communications duties in time of war.

Installed in the Autocrat was a Pye P.T.C.116 V.H.F. "Reporter" radio which was used in conjunction with a

Pye P.T.C.114 radio fitted in a locker aboard the Civil Defence van shown in the photograph below.

The main reason behind the trials is that it is expected after an Atomic attack to be able to approach the stricken area only by air owing to the destruction of roads and railways by blast. In this role the Auster would be used as a reconnaissance aircraft and would be linked to ground-borne rescue teams by means of the radio equipment.



The Auster Autocrat taxiing in during one of the tests carried out by the County of Derby Civil Defence Authorities.

Jungle "Survival School" for Far East Air Force

A SCHOOL for survival where aircrews of the Far East Air Force will learn how to live in—and off—the jungle, is to be established at Royal Air Force Station, Changi, Singapore.

R.A.F. "students of survival" attending a fortnight's course at the school will be taught how to lower themselves from trees 250 feet high—into which they might one day have to parachute—how to make bamboo rafts for crossing rivers and how to snare and prepare wild animals and birds for the pot. Instructors experienced in the ways of the jungle will teach the students how to identify edible and poisonous fruits,

berries, roots and plants, how to build protective lean-to's in the deep jungle and how to deal with sickness brought on by stings and snake-bites. During initial training, the students will "live rough" and take a "toughening-up" course before setting off for the jungle where they will spend some days putting into practice the lessons they have learned about jungle survival. Specimens of poisonous and non-poisonous reptiles, and plastic reproductions of edible and inedible fruits and roots will be used for instructional purposes at the school, where the pupils will also learn

(Continued on page 19)

A Holiday on the Great Barrier Island

by Col. H. K. Christie

These brief notes describe the pleasures that can be enjoyed by those who are fortunate enough to own an Auster aircraft—which will bring within their easy reach those otherwise inaccessible beauty spots about which less happy mortals can but dream in the fireside chair—their heads in the clouds, but their feet on the mantlepiece!

IN A country such as New Zealand, where two-thirds of the surface are mountainous, a journey by car from Wanganui on the west coast (N. Island) to Thames in the North-East, or Auckland in the North, is a day-long affair, though roads are good. Then there is the wide stretch of the waters of the Hauraki Gulf to cross before reaching the Great Barrier

Island—either by the twice-weekly launch which carries mail and supplies to the 200 settlers, or by charter plane from the Auckland Aero Club.

The Great Barrier Island of New Zealand should not be confused with the Great Barrier Reef of Australia, which is a coral reef stretching for 2,000 miles along the Queensland coast.

There is no coral at the Great Barrier Island (N.Z.) which is a rocky outpost of the Colville Ranges in the Coromandel Peninsula. The island is the eastern strategic outpost of the City of Auckland, and harbours an aerodrome of the R.N.Z.A.F. Once it was covered in the northern part with forests of the giant Kauri tree, but these were ruthlessly depleted by the

AIR SERVICE TRAINING

BRITAIN'S AIR UNIVERSITY

Now offers Pilot and Engineer training on
HELICOPTERS

FLYING COURSES for:

Private Pilot's Licence
Commercial Pilot's Licence
Instrument Rating
Flying Instructor's Certificate

AIRCRAFT ENGINEERING

COURSES for:
Maintenance Engineer's Licences
Specialist Courses

AIR NAVIGATION COURSES for:

Flight Navigator's Licence
Airline Transport Pilot's Licence
Senior Commercial Pilot's Licence
Commercial Pilot's Licence

RADIO/RADAR COURSES for:

M.T.C.A. Aircraft Radio Officer's Licence
M.O.T. Radar Maintenance Certificate

Write for details to:

THE COMMANDANT, AIR SERVICE TRAINING, LTD.
HAMBLE, SOUTHAMPTON, ENGLAND.

Phone 3001/9

early timber companies. Now only a few young Kauris survive, and will take centuries to reach maturity.

About twenty miles in length, with steep and rugged coastline, the island rises to a central peak of just over 2,000 feet—Mt. Hobson, or “Hirakimata” of the Maoris. To the N.W. lies the remarkable land-locked harbour of Port Fitzroy, named after a former Governor of New Zealand. Entered through a deep channel but twenty yards wide, this harbour could give a sheltered anchorage to all the fleets of England.

To the south-east on a sloping plain or coastal strip, lies the Great Barrier aerodrome, maintained in first-class order by the R.N.Z.A.F. To the south-west lie the lovely bays of Whangaparapara, Okupu and Tryphena. The Maori word Whanga means “bay”, whilst “parapara” was a soft mud used in dyeing flax. At Whangaparapara was once sited the headquarters of the Kauri Timber Company. Captain Cook refers to the excellence of the Kauri tree for masts and spars; and the boat-builders of today prefer kauri planking to all else for their yachts and launches. Nearly all the noble forest giants have succumbed to the axe, save in the Kauri reservation at Waipoua in the North Auckland province, where a national heritage of Kauri forest is preserved.

Today “the Barrier” is a secluded island of sheep farmers and fishermen. Shoals of fish abound and lobsters are taken by the thousand for the American market—a source of dollars that sadly depletes the crustacean population.

At Fitzroy, Okupu and Tryphena there is accommodation for the tourist and our destination was Okupu, where Mr. and Mrs. Storey provide accommodation for their guests in a row of cabins that open onto the golden sands of the tranquil bay. Shoals of fish

come in with the tide, and are so easily caught that soon the sportsman tires from mere surfeit. The most abundant fish is the snapper, running up to eight or ten pounds in weight for a big one; but there are many other species and oftentimes two or even three may be hooked on your line together. Whilst still alive the snapper has the glinting iridescence of the fire-opal; but soon these colours fade, leaving only the pearl grey of dead scales.

Another little fish is tinted with the brilliant blue of a summer sky. There are also the large “game-fish”—kingfish, sharks and swordfish—but these are more plentiful 100 miles further



Great Barrier Island is a sea fisherman's paradise. This is the big one that didn't get away—an 8 lb. “Snapper”.

north at the Bay of Islands, and 100 miles further south at Tauranga, in the Bay of Plenty. A truly remarkable

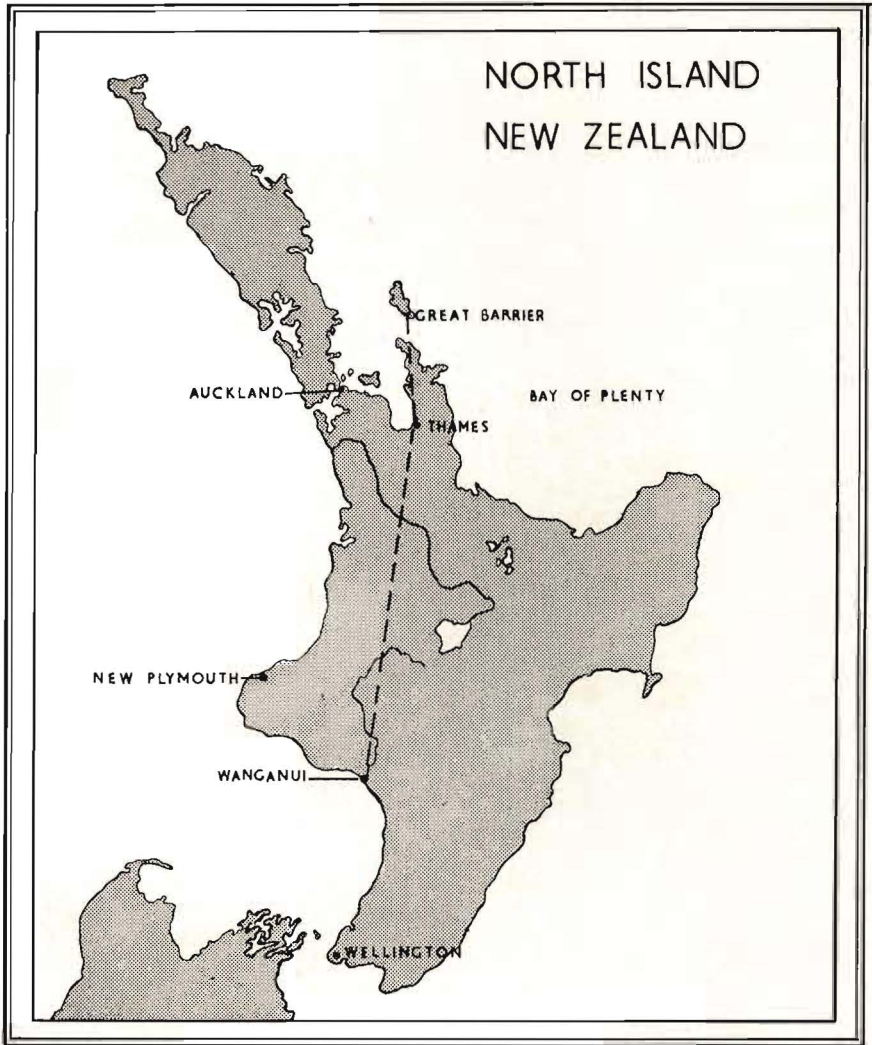

sight is a great shoal of Kawai, feeding on the small fish near the surface, and encompassed in turn by their own enemies. Gulls swarm in thousands overhead to share the small fry, whilst sharks and swordfish attack the shoal from below, driving them up. As these hungry hunters make their attacks from the depths, the frightened fish lash the surface into spray; and

lanes of lashing tails and flying spray run through the shoal to mark the course of the onslaught.

In Mr. Storey's 18 footer, with its little 4 h.p. motor, we cruised south to Tryphena whilst the black and towering rocks slid by, and north to Whangaparapara Inlet, where the native forest still clothes the shores, where gannets plummet into the water and king-

fishers thrive. Trolling a spinner for fish we had the rather unusual experience of catching a gannet which dived upon the lure. The bird was soon reeled in and once more set at liberty.

The accompanying map, shows the course of our Auster Autocrat ZK-AKZ from Wanganui to the little city of Thames. Here my two friends were embarked, and the three of us with luggage and an out-board

Barrier", precipitous and inaccessible save for one small landing cove. It is a bird sanctuary where the native birds can live unmolested by man or animal.

Touching down at the aerodrome we parked AKZ in shelter behind the hangar, and were given a lift in a "jeep" across the rough and stony road to Okupu, where the next few days provided hospitality, swimming, fishing and scenic excursions; and at



Colonel Christie and Auster Autocrat ZK-AKZ at the R.N.Z.A.F. aerodrome on Great Barrier Island off Coromandel, New Zealand.

motor took off and set course for the Great Barrier, passing over the wooded Colville Ranges at 4,000 feet. The blue water and white sands of Mercury Bay passed to starboard, then Gt. Mercury Island—a sheep farm shoaling from the mainland; and soon in bright sunlight we were circum-navigating the Great Barrier Island, studying at leisure the beauties of rocky coast and timbered heights. Twenty miles to the west lay "Little

night rest for jaded nerves to the lapping of the little waves upon the sand.

On the return journey low clouds and rain obscured the coastline and AKZ flew low round Cape Colville and down the Firth through rainclouds to Thames, where my friends disembarked, thrilled with their holiday, and I returned, on compass course, to Wanganui.

(Continued on page 19)



**THESE
SKIDS
WRECK
TYRES**

— — **THIS IS THE WAY TO STOP THEM!** — —

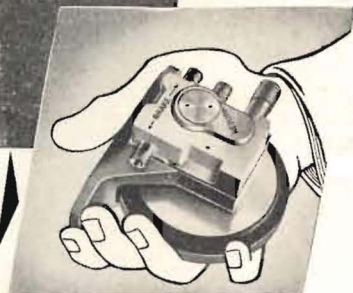

These runway skid marks, hundreds of yards long, are evidence of the destruction of four first-class aero tyres. Had the aircraft that made them been fitted with Maxaret Anti-skid Units there would have been no skids and no tyre damage. The Maxaret, developed by Dunlop, is a device that keeps braking power at a constant maximum (with pilot-control right up to skidding-point) and totally prevents wheel skidding and tyre scrubbing damage. It enables the operator to get more landings per tyre and offers the pilot and passengers added security in emergency. The small, compact Unit, weighing 4.7 lb., fits any size of wheel and makes no additional demands on aircraft services. Full details of the Maxaret are available from the Dunlop Aviation Division.



**DUNLOP MAXARET
ANTI-SKID UNITS**

DUNLOP RUBBER CO. LTD. (AVIATION DIVISION) · FOLESHILL · COVENTRY

SH/611A

Counterpoise fitted in conjunction with Modifications No. 2898, 2899

18

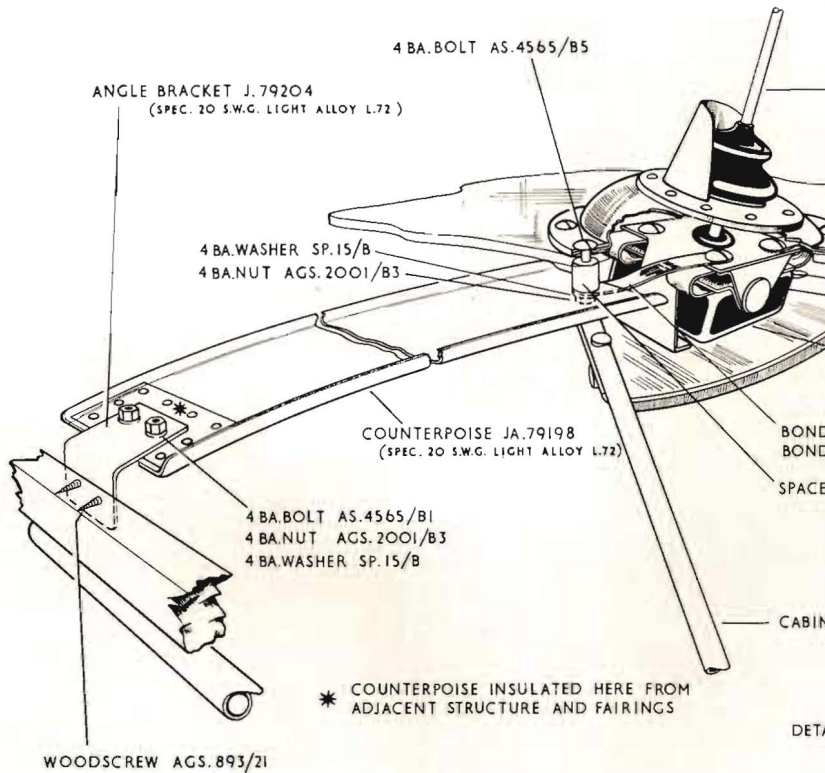

AUSTER SERVICE BULLETIN

Auster Aircraft Limited
Rearsby, Leicester, England

Issue No. 39
December, 1955

INTRODUCTION OF COUNTER-POISE TO AERIAL INSTALLATION

EXPERIMENTAL FLIGHT TESTS have recently been completed on an Aircraft radio installation incorporating an aerial counterpoise. These tests have proved that the range of the radio equipment has been considerably increased.

Details of the modification are illustrated on pages 18 and 20. It will be seen from these that the modification is of a comparatively simple nature, and in view of this, details of material etc., have been included as it is felt that many Auster owners will be able to manufacture the parts required from local sources, rather than order modification kits from us. We shall be pleased however to supply modification kits if required, which will be delivered

as soon as possible after receipt of order.

It should be noted that the modification introducing the counterpoise is only applicable to those aircraft with the aerial mounted above the front cabin.

On aircraft fitted with sunblinds a further slight improvement in range may be effected by replacing the metal rods in the blinds with suitable rods in non-metallic material.

A further modification has been raised to revise the sunblind attachments, when the aerial is mounted in the forward position with its counterpoise. Due to restricted space in this issue details of this modification will be published in the next edition of the Auster News.

(Continued from page 16)

This is but one of many trips made in AKZ, to all parts of New Zealand—1,000 miles long. To an Auster any good paddock is a landing field; although many good aerodromes exist throughout New Zealand, whilst “met” and other information is freely available from the Civil Aviation Dept. Even the telephone calls for air movements are “collect.”

AKZ, the first Auster in New Zealand still flies and is now the property of Mr. S. J. Lister of Milford, Temuka, in S. Canterbury. Using only 4 gallons of 80 octane per hour for her 100 h.p. Cirrus minor engine, AKZ could remain airborne for 7 hours. Engine and airframe never gave a moment's anxiety. Now she is succeeded by AXE, an Aiglet with Gypsy major, and the Auster tradition is carried on.

There are 35 private owners in New Zealand, excluding clubs and firms; and a private owners' association has been formed. These are the

“fortunate few”, and many of them fly Austers. There are farmers who “go round the sheep” in the Auster, and accomplish in half-an-hour what would normally take all day on a horse.

To our earthbound friends we can but express the hope that some day they may “have a trip” in an Auster.

(Continued from page 12)

how to fashion hunting and fishing equipment from bamboo and vine as part of their training in jungle-craft.

The school will be directed by the Command Physical Fitness Officer, Squadron-Leader G. A. Podevin, who recently led a team on operation “Jungle Trek” through hitherto unknown territory in British North Borneo. All the instructors at the Far East Air Force Survival School will have considerable experience of life in the jungle and will have accompanied units of the Security Forces on operations against the Communist terrorists in Malaya.

MOD. No. 30

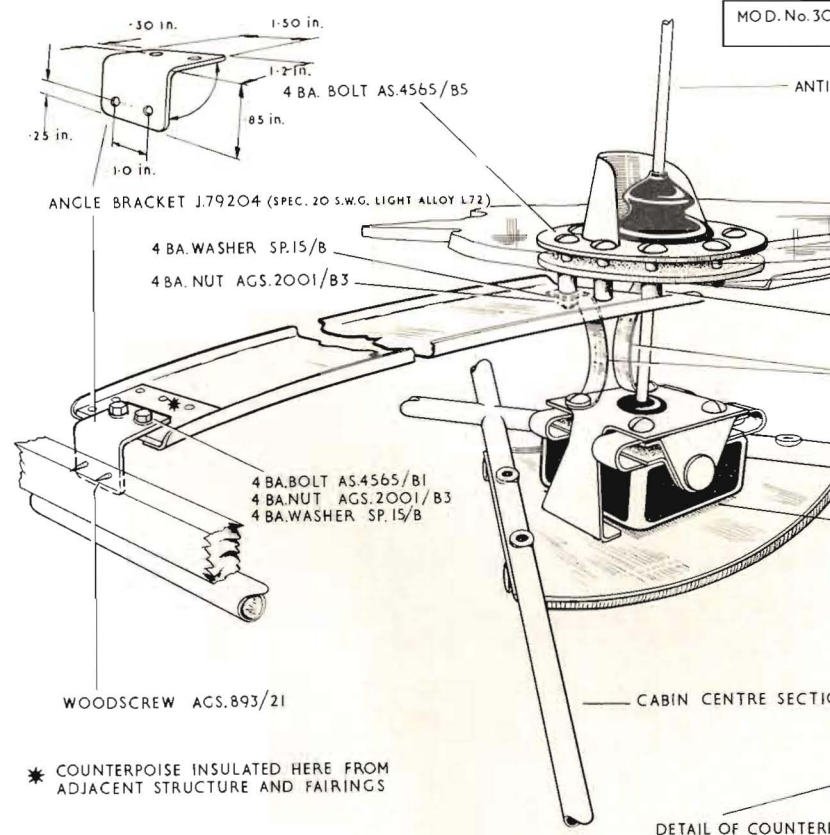

Counterpoise fitted in conjunction with Modifications No. 2899, 2902

20

* COUNTERPOISE INSULATED HERE FROM ADJACENT STRUCTURE AND FAIRINGS

DETAIL OF COUNTER



The Cirrus Bombardier, power unit of the Auster A.O.P.9 is in production for the Royal Air Force. It is a 4-cylinder direct injection engine rated at 180 h.p. and can deliver 170 h.p. when operated on ordinary motor car fuel.

The reliability of the Cirrus Bombardier has been proved under the most arduous Service conditions. Its direct fuel injection system, which is designed for economy, provides instant response to rapid throttle handling.

Blackburn and General Aircraft Limited.

ENGINE DIVISION

43 BERKELEY SQUARE, LONDON, W.1

TITANINE

Aircraft Finishes...

are now used on
AUSTER AIRCRAFT



Throughout the world,
Auster aircraft are operating
in widely varying conditions, in
many different roles. Titanine
Finishes now provide colour and protec-
tion for these famous and versatile aircraft.



TITANINE LIMITED

Colindale, London, N.W.9 Telephone: Colindale 8123 (6 lines)

Factories: London. Surrey. Scotland